

# SERVICE MANUAL

---

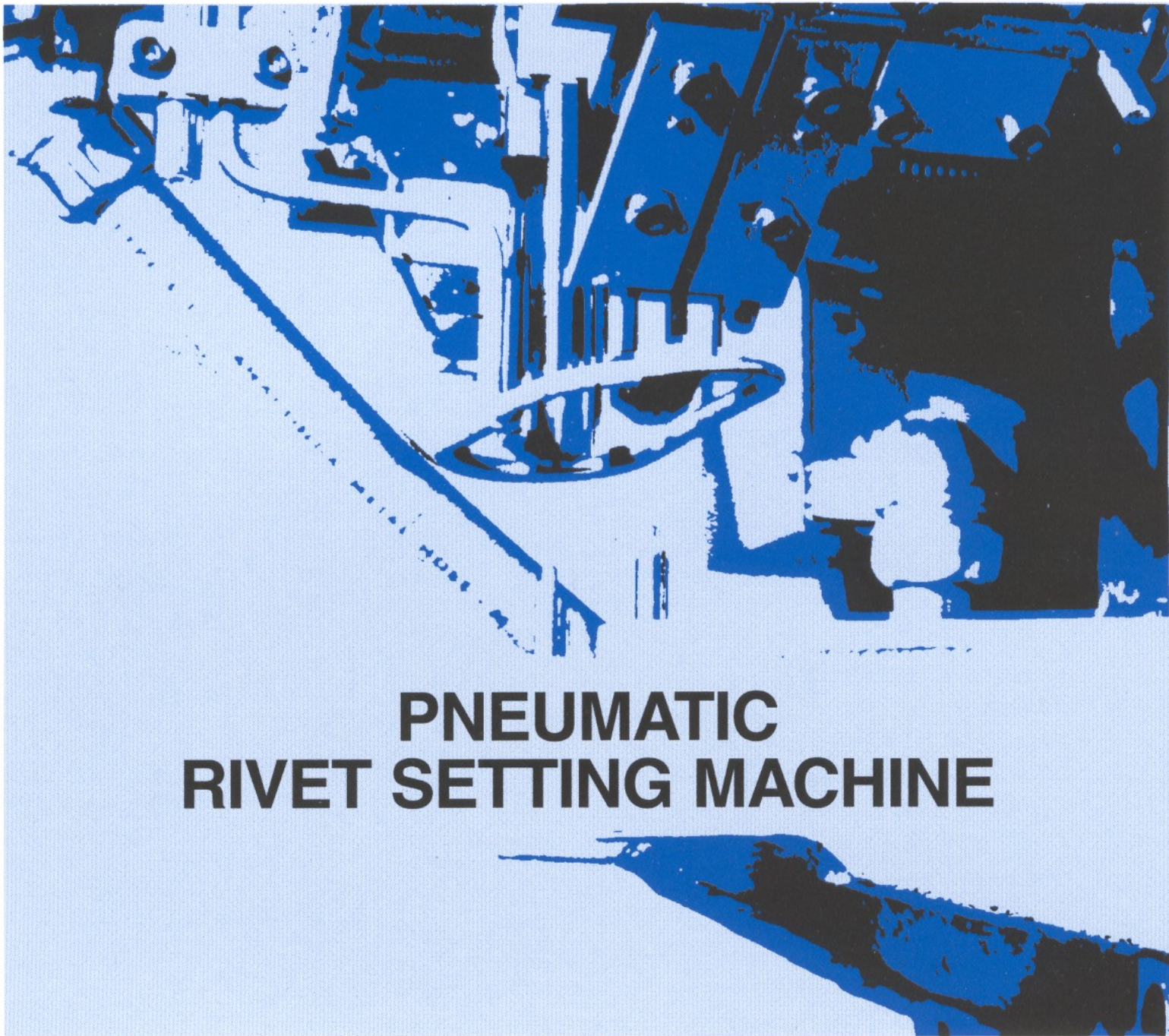

## PNEUMATIC RIVET SETTING MACHINE



Chicago Rivet

---



---

---

## Warranty

The Chicago Rivet & Machine Company warrants automatic rivet setting machines, and parts (excluding Tools Driver Jaws & Anvils) to be free from defects in material and workmanship under normal use and service for a period of one (1) year from the date of shipment by the Company. The Company's obligation under this warranty is limited to repair or replacing, at its option, any goods which upon inspection by the Company shall disclose to the Company's satisfaction to have been defective in material or workmanship. The Buyer must return the goods to the Company's designated factory, shipping charges prepaid, with complete information as to alleged defects and the installation, operation and service of the goods.



## Table Of Contents

Section		Page
	Warranty & Table of Contents . . . . .	Inside Cover
1	Introduction . . . . .	1
2	Handling & Safety Precautions . . . . .	1
3	Set-up & Make Ready . . . . .	2
4	Operation & Description . . . . .	3
5	Adjustments & Parts Replacements . . . . .	4-5-6-7
6	Inspection & Lubrication . . . . .	8
7	Rivet Size Changeover . . . . .	9
8	Troubleshooting . . . . .	10-11-12
	Length & Clinch Allowance . . . . .	Back Cover

Chicago Rivet pneumatic machines, are designed especially for riveting materials which are fragile, or which vary in thickness from one piece to another. They also are ideal for multi-rivet setting applications. In addition, Chicago Rivet manufactures an extensive line of mechanical rivet-setting machines, both electrically and foot-powered.

This *Set-up & Service Manual* provides all general descriptions and instructions for the unpacking and set-up, inspection and adjustment, lubrication and troubleshooting of *all models of air-operated rivet-setting machines* manufactured by Chicago Rivet & Machine Company. It also outlines procedures for rivet size changeover. Where specific information or drawings for a particular model are referred to, consult the *Parts & Assembly Prints* for your model of machine. These *Parts & Assembly Prints, one for each model of machine*, and this *Set-up & Service Manual* are organized to be *complementary*.

Before attempting to uncrate, set up, adjust or operate the machine, be sure to *read and understand* all instructions, especially all safety precautions. They will enable you to put the machine into operation efficiently, safely, and without machine damage. The manual is concise and the short reading time required will be more than offset by savings in set-up time.

All Chicago Rivet machines and accessories are designed for a long life of high production, trouble-free service, and are warranted for a period of one year (see warranty text left), but they must be given the inspections and adjustments, lubrication and cleaning as specified in this manual. *By carefully following procedures and maintenance* outlined here, you can be assured of the best possible results from your Chicago Rivet machine, and also avoid personal injury or damage to the machine during set-up, operation and maintenance.

**General Safety:** Keep in mind one very important point, about rivet-setting machines; they are basically *top-heavy*—especially *pedestal* machines. Usually, *safe* practices also avoid *machine damage* as well as *personal injury*, whether in handling, set-up, adjustment or operation of the machine. Never wear jewelry, long sleeves, or neckties in handling or operating machinery. Always wear face mask or respirator and use ventilation fans if necessary when using toxic solvents or other chemicals, when cleaning machines.

**Uncrating and Handling:** Immediately upon arrival, check the outside of crates before opening, for visible evidence of rough handling or damage (sometimes an important point in the success of damage claims with common carriers). If there is, make note of it with a short description in signing the carrier's bill of lading, or *don't sign at all* until checking with officials of the carrier. First, uncrate the top boards, and then sides, using tools carefully to avoid damage to machine. Leave base of crate intact, with machine on it, and inspect machine for *concealed damage*.

Check the bill of lading against your purchase order and invoice to be sure all items were delivered, including the box of tools (extra Driver, Jaws & Anvil) fastened within the crate.

Use a fork lift or hand truck under the base to transport the machine. Keep in mind one very important point, rivet-setting machines are *top-heavy*—especially *single-pedestal* machines. Because it is top-heavy, secure the upper machine column to the forklift with a heavy strap, belt or rope. Do *not* use a *slings* in handling the machine; and do *not* use the *hopper* or *raceways* as a *handhold*. Wear safety shoes and gloves in handling the machine, and remove any loose items of clothing and all jewelry, especially rings. Slowly move the machine, on the crate base, to the desired location. Then move the machine off the crate base to the floor or bench.

**Operating Safety:** Be sure anyone allowed or assigned to operate a Chicago Rivet pneumatic machine: (1) is thoroughly familiar with machine operation and has read and understands Page 3, "Operation and Description", of this service manual; (2) wears *safety glasses* and *safety shoes*; (3) removes or secures all items of loose clothing; (4) removes all rings and other jewelry; and (5) always wears a face mask or respirator, and uses ventilation fans if necessary, when using toxic solvents or other chemicals, for cleaning machines.

Be sure, before anyone touches any machine component for servicing and maintenance of machine, that power is shut off/disconnected, and safeguarded so it *cannot be mistakenly turned on* by anyone, except at the direction of the person doing the servicing.



# Set Up & Make-Ready

## Set-Up Procedure:

1. Make certain intended location of machine leaves *ample clearance space around machine* for both operator and set-up and maintenance personnel.
2. Level machine, and anchor with bolts to floor, (*but leveling need not be perfect*). *Benchtype machines must be solidly attached.*
3. Clean all preservative grease from machine with degreasing fluid or similar solvent (avoid gasoline which is explosive and toxic). Also clean raceways of dirt with brush and cleaning fluid.
4. Connect the air line to air supply and adjust pressure as indicated on tag. Air supply line diameter must match port size in filter.
5. Completely inspect and lubricate machine according to the lubrication chart and schedule on Page 8 "Inspection & Lubrication". Use SAE 20 oil for lubricating the machine, and fill the air line lubricator with SAE 10 *non-detergent* oil. **DO NOT LUBRICATE** raceways.

6. Connect the electrical control panel to the electrical power supply (be sure voltage, amperage, phase and frequency (Hertz) match the requirements of the machine).

This hook-up should be done by a *competent electrician*. Be sure *not* to cover the identification plate of the machine.

7. With power turned *off*, make all inspections in the order outlined below and any adjustments necessary. Follow procedures on Page 5 and 6. "Adjustments & Part Replacements".

8. Place a work assembly on anvil and use manual override on air valve to bring driver down to riveting position, and raise anvil until assembly is snug between driver and anvil. Lock anvil at this spot.

9. Return override to normal position.

10. Fill hopper with rivets to proper level (half full) and release transfer-slide lock. Transfer a rivet into the jaws.

11. Turn control switch "on", and trip machine.

12. Check rivet clinch for tightness. If too tight or too loose follow the procedure outlined in *Rivet Clinch* (Page 5) "Adjustments & Part Replacement" to adjust tightness of rivet clinch.

13. Machine is set up and ready for production which, at above recorded air pressure setting, will yield the final-adjusted clinch.



# Operation & Description

## a. Scope of Machine

**Capabilities:** Chicago Rivet pneumatic machines can set rivets of a wide range of size and head style. In some applications they require, (for slight variations in rivet shank length) machine adjustments; in other cases (for variations in shank diameter or head style) a changeover to a new set of various machine components is required. These changes are completely outlined on Page 9 "Rivet Size Changeover". In addition, machine maintenance, common operating adjustments must be made from time to time, but no special tools are required.

The same type of component changeover expands machine versatility, adapting it for setting eyelets, drive screws, tacks, grommets and other similar fasteners. Components and accessories available for changeover include a wide variety of horns, anvil holders and special anvil fixtures. Contact your Chicago Rivet representative, or the home office for complete current information.

**b. Elements of Operation:** These machines provide the resilient force of air for the rivet-setting process, but the complete operating cycle is electrically initiated with a footswitch or handswitch(s).

Because the electric control relay is re-energized by release of the switch(s), each rivet-setting cycle of operation requires an individual operation of the switch(s) if the time-delay adjustment of the control relay is set correctly. This also is the only required adjustment in the electric control panel (see Page 5-Clinch Adjustment).

A four-way air valve is controlled by a single electric solenoid which is energized by the switch(s). In turn, the air valve controls air entering the air

cylinder. The air forces a piston inside the air cylinder to move the attached piston rod and plunger, forcing the driver against the rivet held in the jaws, and upsetting the rivet against the anvil. The anvil is held in an anvil holder, horn, or fixture supported by the horn, which is attached to the machine head or column. The air valve is equipped with a manual operation control, which can be used while making machine adjustments such as tightness of the rivet clinch. Exhaust air noise is reduced with a muffler. The air valve body and pilot assembly can be removed for servicing without disturbing piping, and all air connections are made on the valve base.

## c. Major Components: (Figs. 2 & 3)

**Anvil**—actually determines the shape and quality of the clinch because it does the forming or upsetting of the rivet. It is a factory-assembled unit consisting mainly of the anvil shell, nut, spring, and a pilot. It is one of the most important accessories to the machine, and is available in many styles and lengths. Some are one piece solid types. The rivet presses against a pilot as it is guided through the assembly until it meets the anvil shell, which upsets or forms the rivet to form the clinch.

Because the tightness of clinch is adjusted with the anvil (raising/lowering it until the clinch is satisfactory), it also requires machine adjustments (see *Clinch*, Page 5.)

**Jaws & Driver**—hold the rivet in place and force it against the anvil, setting the rivet.

**Raceways & Transfer Slide**—deliver the rivet from the hopper to the jaw. The raceways are a pair of back and lower plates which direct the rivets from the hopper to the jaws. The transfer slide is spring loaded and actuated by the transfer slide lever. It shuttles the rivet from upper to lower raceway once each operating cycle.

## Power/Actuating

**Mechanism**—consists of air line attachments from an outside air supply (on the machine), cylinder/piston rod, connecting link, and plunger lever which operates the jaw and driver. These are controlled by the air valve and pressure regulator and gauge. The system also is equipped with exhaust air muffler, air lubricator, and filter with drain cock.

**Hopper**—feeds rivets, synchronized with the rivet-setting operation, through a slotted selector bowl, into the upper raceway. Driving speed is adjustable, with two or three speeds available (depending upon machine model), to accommodate rivets of any shank length up to, but not exceeding, the depth of the hopper bowl slots. A given hopper accommodates *one* combination of *rivet head style* and *shank diameter*. However, it is designed for *quick change* when these rivet requirements vary. Only a few models require the original hopper to be factory-modified. The hopper should not be *overfilled*. For best machine operation, it should be *half* full of rivets.

The hopper is emptied of rivets by removing the knurled nut, spring and flat washer from the hopper shaft. Place a container under the bowl, then slide the bowl off its shaft with a rotating motion to empty. Finally, remove all rivets out of the upper raceway. When assembling the washer over the hopper shaft, the part number of the washer should be visible when in place.

## d. Periodic Maintenance &

**Adjustments:** Machine parts should be inspected periodically for wear or need of adjustment or lubrication. Some parts should be oiled weekly, some even daily. See Page 8 for a complete schedule of required lubrication, and the *Parts & Assembly Guide* for your model of machine.

**e. Replacement Parts:** Chicago Rivet machine parts are stamped with easily identified part numbers of one or two letters and a dash, followed by numerals. Parts are described in the *Parts & Assembly Guide* for each machine. Each machine nameplate shows machine model/serial numbers, and part numbers of the *original* driver, jaws and anvil supplied with the machine. Part numbers, and dates, of any parts changed, added or modified should be recorded on this nameplate. An up-to-date history of the machine is then immediately available right where it's needed—at the machine.



# Parts Adjustment & Replacement

**Figure 1**

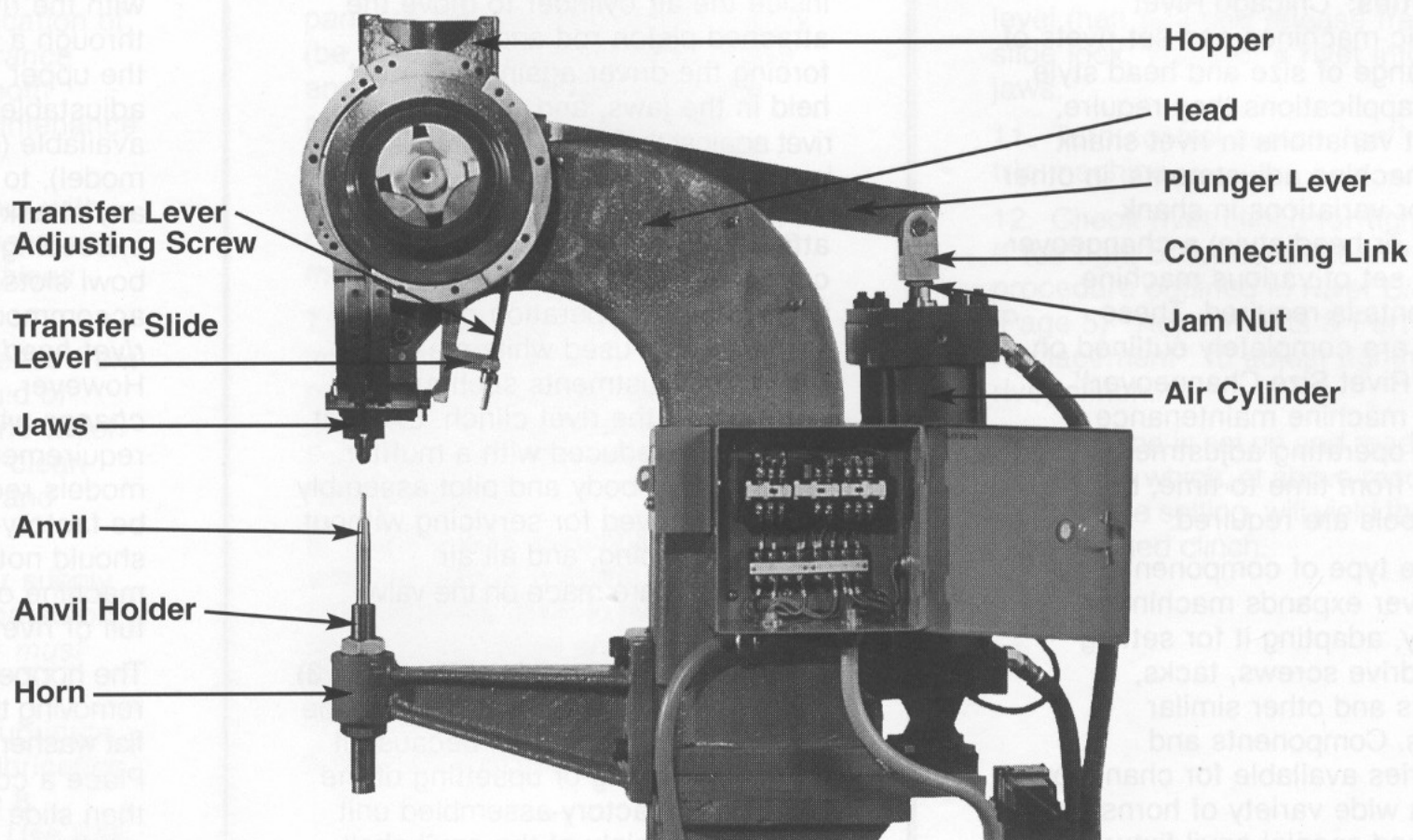

**Figure 2**

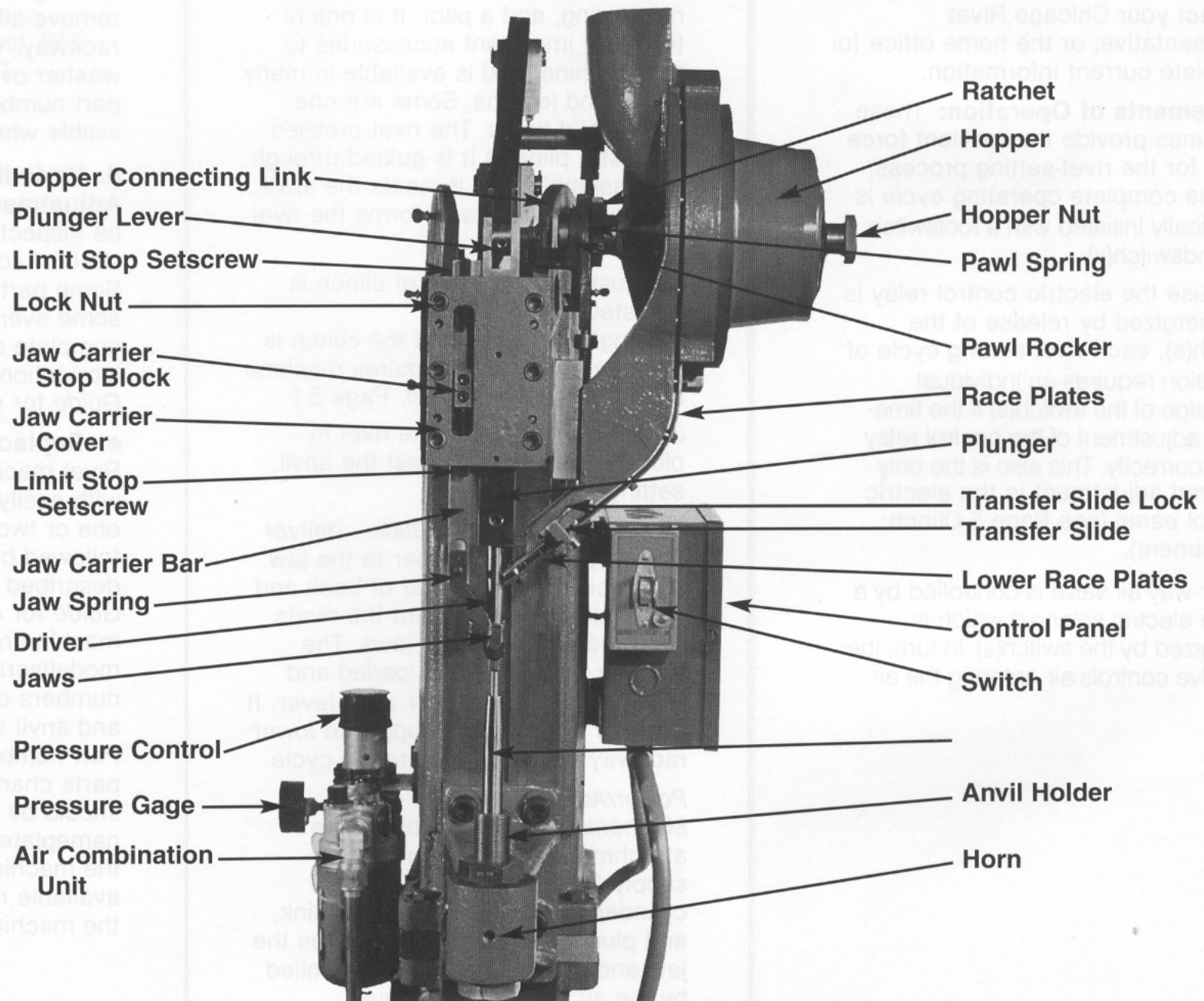



# Adjustments & Parts Replacement

Unplug machine power, if possible, or be sure power is off and cannot be accidentally turned on by someone else. Read *Safety Precautions* on Page 1 before working on machine.

## Clinching Adjustment

*Symptom of Adjustment need: New anvil or replacement.* Rivet is too tight or too loose in assembly, or clinch is off-center.

**Machine Specification:** Distance from top surface of anvil to driver at its lowest position, must be approximately .010" less than the thickness of the work material assembly (the machine compensates automatically for thicker material). Time-delay relay at electrical control panel should be adjusted to the minimum setting consistent with a good, snug rivet clinch.

**Procedure:** If rivet is too tight or loose, adjust rivet clinch by first bringing driver down to lowest position, (see Page 2, Step 8) Then adjust the anvil to the *Machine Specification* (above). Set a few trial assemblies typical of the work material thickness range and inspect rivet tightness in each. If not satisfactory, repeat the procedure to fine-tune the adjustment. If Anvil driver does not center properly when in "down" position, inspect driver, anvil and anvil holder for wear, misalignment, damage, and replace if necessary (see respective section on these components in this Section). If these are in good condition, align

driver and anvil by simply loosening the four capscrews securing head to column, shifting the head as necessary and re-tightening the screws. In cases where the horn is mounted to the head, align horn to bring anvil in line with the driver.

## Anvil Replacement/ Adjustment

Using a rod through the anvil holder, push the old anvil out from below. Check pilot setting of the new anvil as follows: holding anvil assembly in a drill or lathe chuck, remove nut and spring, replace nut. Then check pilot projection distance "B" (as shown in *Pilot Setting* detail drawing, Figure 3).

Figure 3

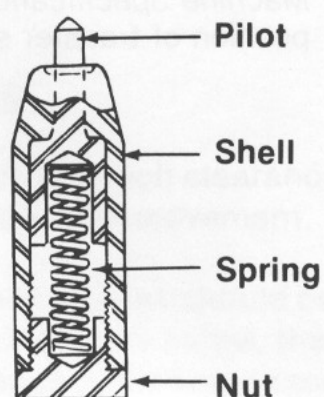

The anvil is a precision made tool designed to clinch semi-tubular rivets. Unless adequate facilities are available in your shop for repair of anvils they should be returned for proper reconditioning or replacement.

**NOTE:**  
Pilots are supplied oversize and must be carefully fitted to the shell. If hole in shell is worn or bell-mouthed it should be relapped before fitting the pilot.

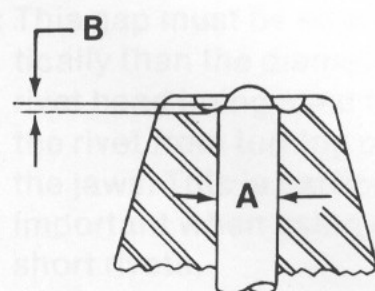

Pilot shown resting against anvil nut

Pilot should be set as shown see table for correct dimensions.

To check pilot setting:

1. Hold shell securely in a drill chuck or lathe chuck and remove nut.
2. Remove spring and replace nut.  
If pilot is too high, grind off bottom of pilot.  
If pilot is too low, grind off bottom of shell.

	A	B
	1/16	.003/.006
	3/32	.003/.006
	1/8	.004/.007
	9/64	.004/.007
	5/32	.004/.007
	3/16	.005/.008
	1/4	.005/.008
	5/16	.006/.010
	3/8	.006/.010

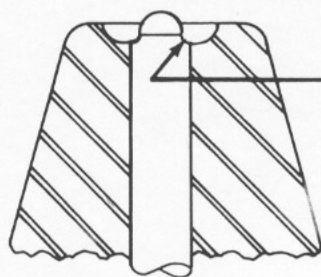

Edge must be sharp.  
Do not grind or polish pilot diameter shown as edge of rivet will be forced into opening and buckle instead of clinching properly. Foreign matter also may settle in crevice causing pilot to lodge in shell.



## Jaws

### Symptom of Adjustment Need:

Rivets may topple and/or tend to feed improperly from the jaws to the work assembly.

**Machine Specification:** In the lowered position, jaws should clear anvil pilot tip or assembly by approximately 1/32 inch, slightly more with longer rivets. In the upper position, it should leave .003 to .005 inch vertical clearance with the bottom surface of the lower race plates. "C" distance (see Figure 4 *Jaw/Driver/Race Plate adjustment* Page 7) from top surface of jaws to bottom of driver should be less than the rivet head diameter.

**Procedure:** At the top and bottom of the plunger cover plate (see Figure 2 *Machine Front View* illustration Page 4), an adjustment sockethead setscrew, secured with a locknut, bears on the stop block of the jaw carrier bar, limiting the bar's vertical movement. Loosen these locknuts, adjust the two limit-stop setscrews until the jaws are set to *Machine Specification* above, then retighten the locknuts to secure the setscrews. At the same time, make sure the screw and nut securing the jaws and auxiliary jaw springs (the inward-bowed leaf-type centering springs) to the carrier are tight. These springs prevent "spitting" of the rivets in the jaws.

## Driver

### Symptom of Adjustment Need:

Driver tends to drop slightly and, possibly, rivets fail to drop properly into the jaws. Both problems are caused by long-term wear on plunger, lever, link & yoke pins/holes.

**Machine Specification:** .003 to .005 inch horizontal clearance between driver and back plate of lower race plates, and vertical alignment of the bottom end of the driver with the lower edge of the back plate (the upper plate) of the lower race plate assembly when the driver is set at its vertical "home" position—at the top of its vertical travel (Fig. 4 & 5)

**Procedure:** Loosen the hex jam nut at the upper end of the air cylinder piston rod, and turn the piston rod to increase or decrease its end distance from the plunger lever yoke until the bottom end of the driver is aligned to meet the *Machine Specification*.

## Transfer Slide

### Symptom of Adjustment Need:

Rivets do not feed into lower raceway, even though upper raceway contains rivets, and transfer slide is unlocked.

### Machine Specification:

Approximately 3/8 inch is required between the end of the transfer slide and transfer slide lever to give rivet enough travel time to drop into lower raceway. The transfer slide opening must align with both upper and lower race plates. The transfer slide is spring-loaded, and should move freely with only slight thumb pressure.

**Procedure:** Check transfer slide movement, then adjust transfer slide and transfer slide lever. Adjust if necessary, as follows: first, be sure driver is in *full down* position (see *Driver Adjustment* in this Section). Measure the distance from the end of the transfer slide to the end of the transfer slide lever. Adjust to *Machine Specification* by adjusting position of transfer slide lever.

B	A
000/1000	1/16 Cover
003/005	5/32 Limit Stop
004/007	1/8 Setscrew
004/007	1/8
004/007	1/8 Jaw Carrier Bar
004/007	5/32 Jaw Spring
005/008	3/16 Driver
005/008	1/4 Jaws
008/010	5/16
010/1000	3/8





**Figure 4**

- A:** .003- to .005-inch clearance for vertical driver movement.
- B:** .003- to .005-inch maximum clearance. (Jaws should be as close to the lower race plate assembly as possible without touching them.)
- C:** This gap must be smaller vertically than the diameter of the rivet head being used to prevent the rivet from turning over in the jaws. This is particularly important when using extremely short rivets.

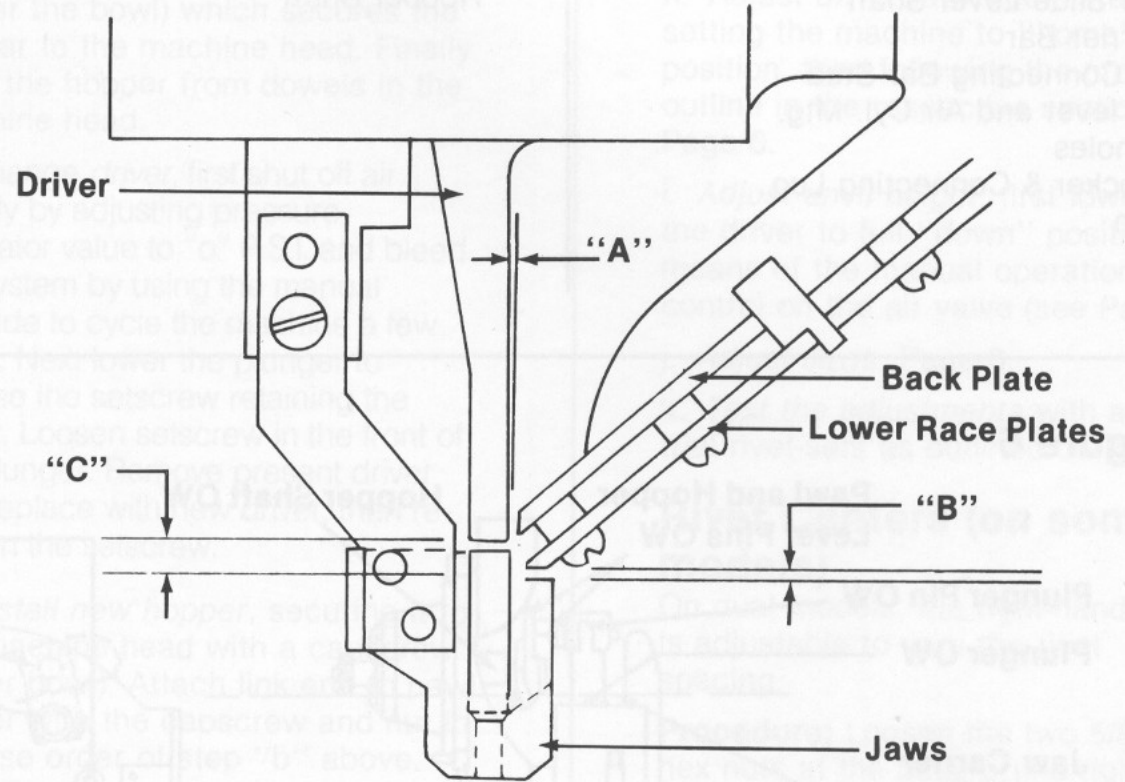

**Figure 5**

- A:** .003- to .005-inch clearance for vertical driver movement.
- B:** Top inlet of jaws should be even with, or slightly below, the upper edges of the lower race plates.
- C:** This gap must be smaller vertically than the diameter of the rivet head being used to prevent the rivet from turning over in the jaws. This is particularly important when using extremely short rivets.

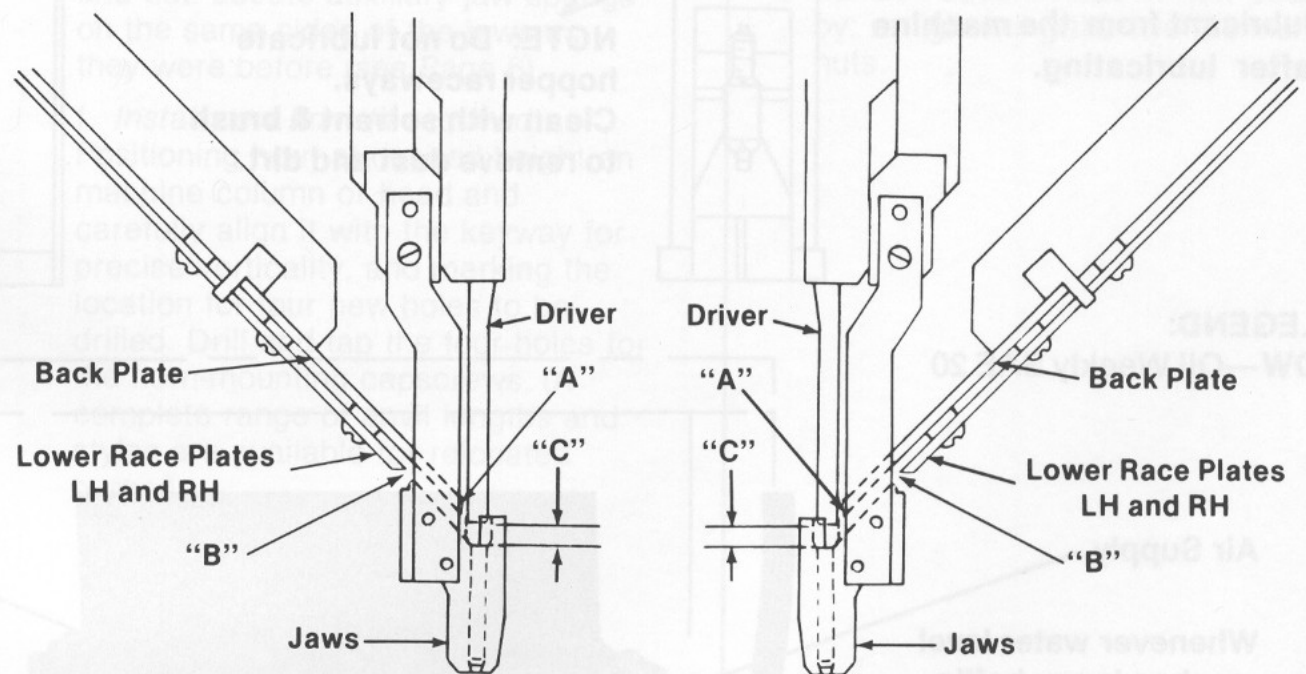



# Inspection & Lubrication

## Lubrication

### Daily Lubrication Schedule:

(with SAE 20 Oil)  
 Transfer Slide Lever Shaft  
 Jaw Carrier Bar  
 Hopper Connecting Bar Stud  
 Plunger lever and Air Cyl. Mtg.  
 Pins/holes  
 Pawl Rocker & Connecting Lug  
 Pawl Pin  
 Plunger

### Weekly Lubrication Schedule:

(with SAE 20 Oil)  
 Hopper Shaft

**Figure 6**

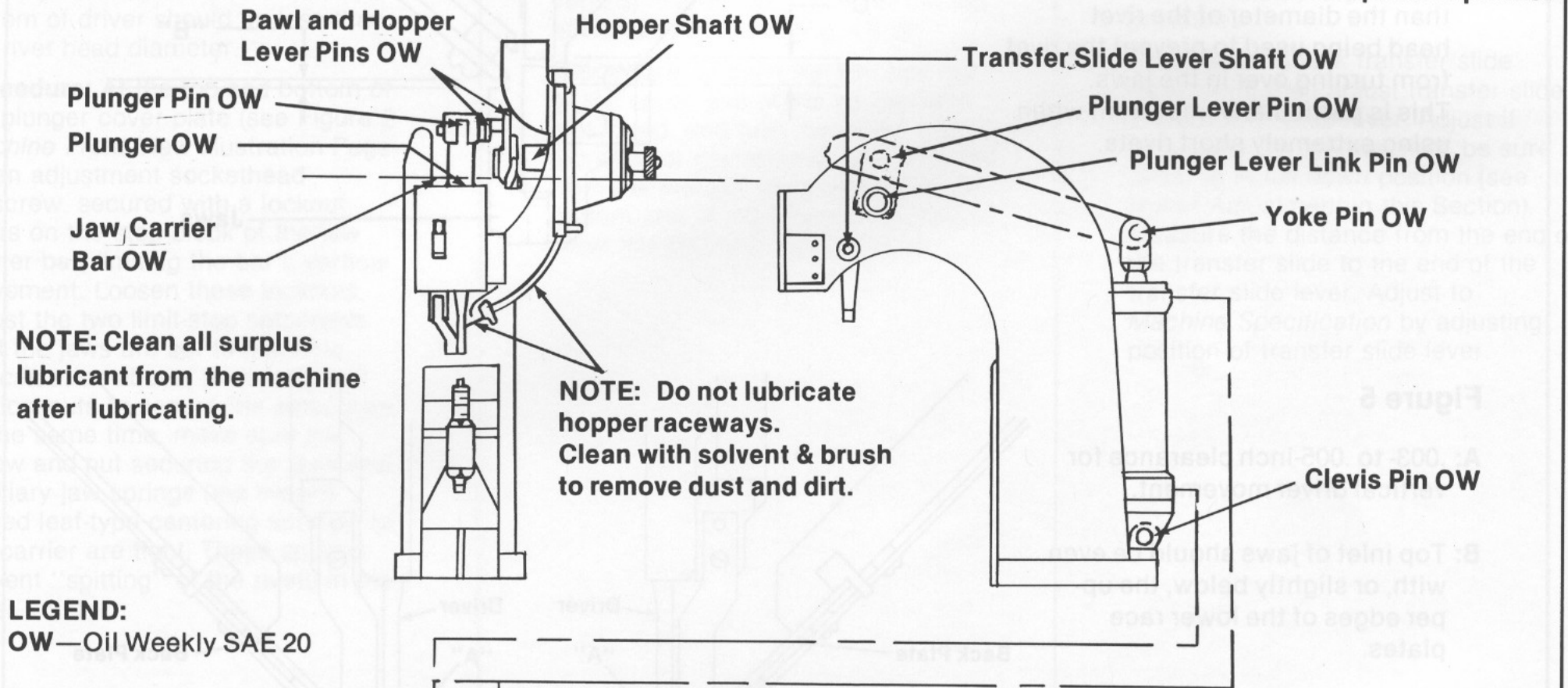

**LEGEND:**  
 OW—Oil Weekly SAE 20

Air Supply

Whenever water level reaches lower baffle plate open drain cock to blow out moisture and sediment.

Air Valve

Excessive oil at exhaust indicates oil flow is set too high.

Oil Fill Plug—can be filled without shutting down air line.

Oil Flow Adjustment—turn stem clockwise to increase oil flow.

Fill to visible rim with SAE 10 non detergent oil. Do not permit oil level to drop below oil feed rod end.

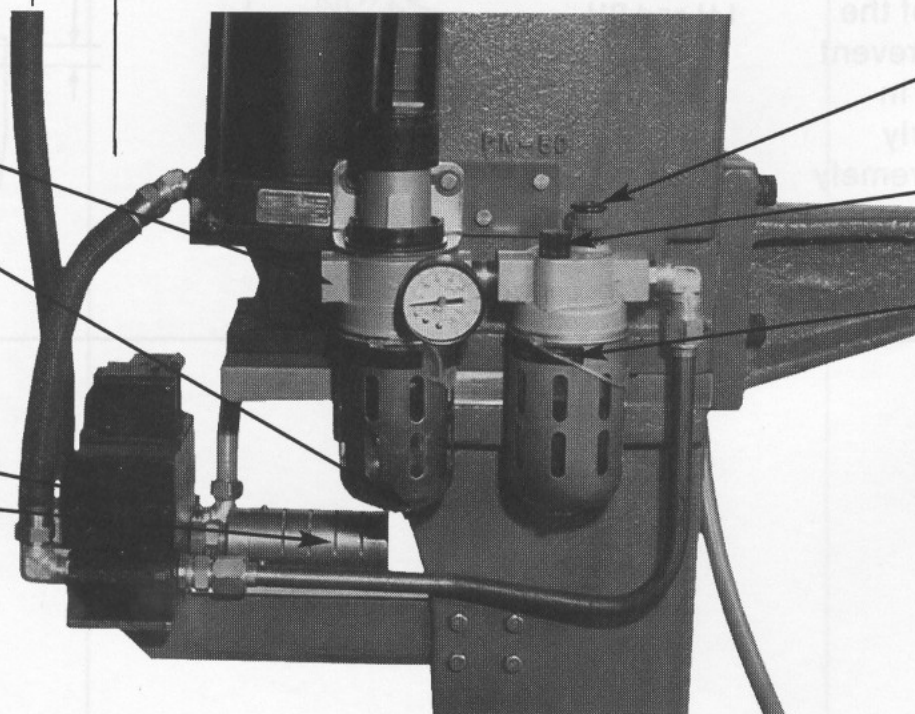



## Rivet Shank Length (Slight Differences)

If rivets of *only* a new length are to be used, changeover of machine components is unnecessary. Merely change driving speed. This is governed by the location of the hopper pawl rocker link in any of three holes (two holes in some models) in the pawl rocker (normally it is in the center one).

**Procedure:** To accommodate slightly longer or shorter rivets simply relocate the link to the hole nearest the hopper shaft (faster operation) for longer rivets, or farthest from the shaft (slower operation) for shorter rivets.

Rivets of a new length may also require an adjustment of the anvil.

**Procedure:** See "Clinching Adjustment" on Page 5.

## Rivet Shank Diameter/ Head Design

If rivets of a different shank *diameter* or of a different head design are to be used, the rivet-setting machine must be modified with new components as listed below.

**Components Required:** Quick change hopper assembly, driver, jaws and anvils; in some cases, also the horn and anvil holder.

### Procedure:

a. *Remove present jaws and their auxiliary springs* by first removing the attachment screw and nut. Empty the hopper of rivets, following the procedure described on Page 3, "Operation & Description"

b. *Remove present hopper*, first removing the link end of the pawl rocker attached with a cap screw and nut. Then remove the cap screw (under the bowl) which secures the hopper to the machine head. Finally slide the hopper from dowels in the machine head.

c. *Change driver*, first shut off air supply by adjusting pressure regulator value to "o" P.S.I. and bleed the system by using the manual override to cycle the machine a few times. Next lower the plunger to expose the setscrew retaining the driver. Loosen setscrew in the front of the plunger. Remove present driver and replace with new driver, then re-tighten the setscrew.

d. *Install new hopper*, securing it to the machine head with a capscrew (under bowl). Attach link end to pawl rocker with the capscrew and nut in reverse order of step "b" above.

e. *Install new jaws* and auxiliary jaw springs on pin, attaching them to the carrier with the old attachment screw and nut. Locate auxiliary jaw springs on the same sides of the jaws as they were before (see Page 6).

f. *Install new horn (if required)*. Positioning horn at desired height on machine column or head and carefully align it with the keyway for precise verticality, and marking the location for four new holes to be drilled. Drill and tap the four holes for the horn-mounting capscrews. (A complete range of anvil lengths and styles are available for relocated horns.)

g. *Change anvils* (see machine Right Side View (Fig. 3) and follow procedure on Page 5).

h. *Adjust driver/jaw/race plates*, first setting the machine to "home" position, then following the procedure outline in the respective section on Page 6.

i. *Adjust anvil height*, first lowering the driver to full "down" position by means of the manual operation control on the air valve (see Page 5).

j. *Adjust Jaws*, Page 6.

k. *Test the adjustments* with a few trial rivet-sets as outlined on Page 5.

## Rivet Centers (on some models)

On dual models, the right-hand head is adjustable to vary the rivet spacing.

**Procedure:** Loosen the two 5/8-inch hex nuts at the base of the right-hand head. Then adjust the right-hand head position for the desired rivet spacing by turning the crank handle. Secure head in new position by: re-tightening the two 5/8-inch hex nuts.



<b>Malfunctioning Rivet Feed</b>			
<b>Problem:</b>	<b>Is with:</b>	<b>Caused by:</b>	<b>Corrected by:</b>
Rivets not feeding into upper raceway	Hopper or raceway	Hopper not connected, (or)	Connect hopper.
		Hooper bowl slot or upper raceway jammed with odd-size rivet or foreign matter, (or)	Loosen hopper bowl, pulling it outward on shaft, and removing obstruction with pointed wooden stick (metal may damage it).
		excessively worn hopper.	Replace with new hopper.
Rivets not feeding from upper raceway	Transfer Slide	Locked transfer slide, (or)	Unlocking transfer slide.
		binding transfer slide, (or)	Adjusting transfer slide, Page 6.
		incorrectly adjusted transfer slide lever	
Rivets tumbling in jaws	Driver (or)	Driver set too high	Adjusting driver (see Page 6)
	jaws	Rivets too short for jaws, (or)	Changing jaws to correct style (see Pg. 6).
		raceway damaged by jaws	Remove burrs from damaged race.
		Jaws set too low, (or)	Adjusting jaws (see Page 6)
		misaligned jaws, (or)	Align jaws & aux. jaw springs.
		worn jaws.	Replacing with new jaws
Rivets "spitting" out of jaws	Rivet not seating in jaws, (or)	Rivet tumbling in jaws	(see above corrections for "tumbling rivets") Page 6.
	jaw bar (or)	Excessive jaw bar spring (or)	Replacing with lighter spring.
		binding jaw bar.	Removing jaw bar, cleaning and replacing then lubricating.
	jaws (or)	Jaws incorrectly paired (or)	Installing jaws with matching numbers. (see Page 6)
		worn jaws, (or)	Replacing with new jaws Page 6.
		incorrect jaw travel, (or)	Adjusting jaws (see Page 6)
		jaws loose on bar, (or)	Tighten nut on screw
		jaws loose on springs (or)	Tighten or replace jaw rivets
		jaws incorrect for rivet size.	Replace with correct jaws for rivets being used (see Page 6)
	auxiliary jaw springs (or)	Jaw springs too weak, (or)	Increasing the amount of "bow" in springs. Replace with heavier springs.
		jaw springs installed backwards.	Reverse direction of "bow" in springs.
	driver	Driver too long, (or)	Replace with correct driver. (see Page 6).
		driver tip too large for rivet head, (or)	Replace with correct driver
		bent driver	Replace driver



<b>Malfunctioning Part Or Machine</b>			
<b>Problem:</b>	<b>Is with:</b>	<b>Caused by:</b>	<b>Corrected by:</b>
Machine does not trip	Power (or)	Power disconnected, (or) Low air P.S.I. low air pressure	Turning control panel switch to "on", or connecting electrical power Increasing air pressure
	binding in machine component, (or)	Linkage binding	Checking components for binding, then adjusting appropriate machine components.
Machine trips but fails to cycle	machine cycling	Incorrect setting on time delay relay	Increase dwell time on relay
Pilot sticks in "down" position	Pilot (or)	Pilot set too low, (or)	Adjusting pilot setting (see <i>Anvil</i> Section 5,
		bent pilot pin.	Replacing pilot (see <i>Anvil</i> , Section 5)
	anvil	Dirt or foreign material collected in anvil, (or) broken anvil spring,	Disassembling anvil, cleaning, lubricating and reassembling. Replacing anvil spring (see Page 4)

Part	Material	1/2"	3/8"	1/4"	3/16"	1/8"	3/32"	1/16"	3/64"	1/32"
CLINCH	RAJUBUT MESH	.032"	.045"	.055"	.062"	.070"	.080"	.090"	.100"	.110"
ALL	DRY AND LUBRICATED		.062"	.070"	.080"	.090"	.100"	.110"	.120"	.130"
DIAMETER OF RIVET IN ASSEMBLY		.067"	.070"	.080"	.090"	.100"	.110"	.120"	.130"	.140"
DRILL NUMBER		15	18	21	24	27	30	33	36	39

Problem:	Is with:	Caused by:	Corrected by:
Jaws break	Jaws	Incorrectly adjusted jaws	Adjust jaws setting (see Page 6)
Pilot breaks (or)	Machine operator	Operator striking pilot with work	Instructing operator in more careful handling
	work assembly	Work material pushing sideways on pilot.	Installing a resting fixture to support load and hold assembly level





## Imperfect Rivet Formation

<b>Problem:</b>	<b>Is with:</b>	<b>Caused by:</b>	<b>Corrected by:</b> (see reference for details)
Rivets marked by jaws	Jaws/springs	Unpolished jaws, (or)	Polishing the jaws.
		jaw springs too strong (or)	Easing the bow in auxiliary jaw springs
		jaws being set too low.	Adjusting the level of jaws (see Page 6)
Rivets marked by driver	Driver	Radii of driver and rivet not matching, (or)	Changing driver to the correct one for rivets being used.
	(or)	driver diameter too small (or)	
	clinching	driver edge too sharp.	Buffing the driver tip.
Poor clinches	Anvil	Excessive force required to clinch the rivet.	Adjusting the clinch (see Page 5) by lowering anvil.
		Worn out anvil, (or)	Replacing with new anvil.
		improperly set anvil, (or)	Adjusting the anvil (see Page 5)
		anvil misaligned with driver	Adjusting the driver (see Page 6) Align Driver to Anvil
	(or)		
	incorrect anvil clinch diameter	Checking with the Chicago Rivet office.	
rivet	(or)	Incorrect rivet length	Changing to rivet of correct length. (see back cover)
		incorrect hole size in work assembly, (or)	Checking chart (back cover) for correct hole size.
		defective rivet hole	Return sample lot to Chicago Rivet for analysis.

## Machine Part Breakage

<b>Problem:</b>	<b>Is with:</b>	<b>Caused by:</b>	<b>Corrected by:</b>
Jaws break	Jaws	Incorrectly adjusted jaws.	Adjust jaws setting (see Page 6)
Pilot breaks	Machine operator (or)	Operator striking pilot with work.	Instructing operator in more careful handling.
	work assembly	Work material pushing sideways on pilot.	Installing a resting fixture to support load and hold assembly level.



## RIVET LENGTHS

All rivet lengths except countersunk head rivets are measured from the underside of the head to the end of the shank. In applications involving countersunk head rivets, overall length is measured from the top of the head to the end of the shank. AND length under head must also be specified.

**EXAMPLE . . .** If a semi-tubular rivet of 1/8" dia. has been selected the length should be established as follows:

Combined Material Thickness . . . .110  
 Clinch Allowance . . . . .062  
 Rivet Length . . . . .172 = 3/16" Long

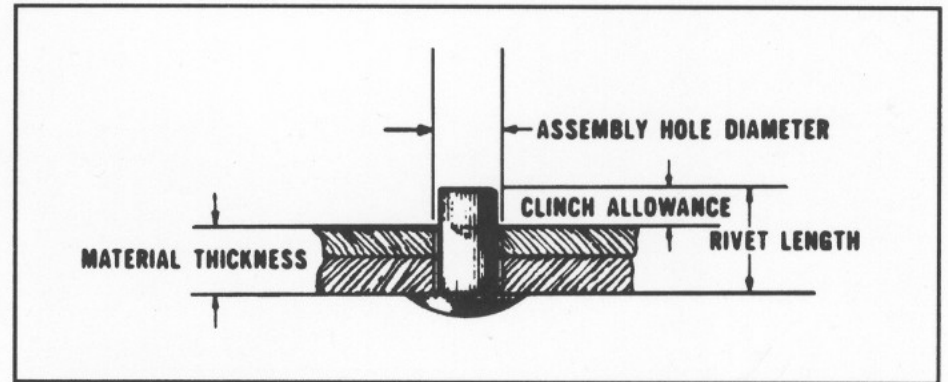

## CHART OF STANDARD CLINCH ALLOWANCES

As a guide in determining proper rivet length, Chicago Rivet engineers have compiled a chart of Standard Clinch Allowances for the most popular rivet diameters. The term "clinch allowance" applies to the part of the rivet extending beyond the material thickness of the assembly. (See illustration above.) The listed clinch allowances are considered minimum. To determine rivet length, add combined material thickness and clinch allowance, then use the next high applic-

able increment. Rivets with body diameters from .060 to .098 are available in 1/64" length increments; 1/8" and larger diameters in 1/32" length increments.

**CAUTION:** While long usage proves it generally satisfactory, this chart should be used as a guide only. Before recording the rivet length permanently, rivet and test a sample assembly. Certain assembly materials and various other conditions often cause a deviation from the established standard clinch allowances.

RIVET SHANK DIAMETER		.060"	.065"	.088"	.098"	1/8"	9/64"	5/32"	3/16"	7/32"	1/4"	5/16"	3/8"
CLINCH ALLOWANCE	SEMI TUBULAR	.032"	.032"	.045"	.055"	.062"	.093"	.093"	.110"	.140"	.156"	.187"	7/32"
	SPLIT AND DEEP HOLE			.062"	.078"	.093"	.125"	.125"	.156"	.175"	.187"	.210"	—
DIAMETER OF HOLE IN ASSEMBLY		.067"	.070"	.093"	.104"	.128"	.152"	.165"	.196"	15/64"	17/64"	21/64"	25/64"
DRILL NUMBER		51	50	42	37	30	24	19	9	15/64"	17/64"	.21/64"	25/64"







Chicago Rivet & Machine Company • P.O. Box 3061 • 901 Frontenac Road • Naperville, Illinois 60566-7061  
Telephone (630) 357-8500  
[www.chicagorivet.com](http://www.chicagorivet.com)